



SYMPOSIUM

The Evolution of Mechanical Properties of Conifer and Angiosperm Woods

Timothy E. Higham ^{*,1}, Lars Schmitz[†] and Karl J. Niklas [‡]

*Department of Evolution, Ecology, and Organismal Biology, University of California, Riverside, CA 92521, USA; [†]W.M. Keck Science Department, 925 N. Mills Avenue, Claremont McKenna, Pitzer, and Scripps Colleges, Claremont, CA 91711, USA; [‡]School of Integrative Plant Science, Cornell University, Ithaca, NY 14853, USA

From the symposium “Integrating ecology and biomechanics to investigate patterns of phenotypic diversity: Evolution, development, and functional traits” presented at the annual meeting of the Society for Integrative and Comparative Biology virtual annual meeting, January 3–February 28, 2022.

¹E-mail: thigham@ucr.edu

Synopsis The material properties of the cells and tissues of an organism dictate, to a very large degree, the ability of the organism to cope with the mechanical stresses induced by externally applied forces. It is, therefore, critical to understand how these properties differ across diverse species and how they have evolved. Herein, a large data base ($N = 84$ species) for the mechanical properties of wood samples measured at biologically natural moisture contents (i.e., “green wood”) was analyzed to determine the extent to which these properties are correlated across phylogenetically diverse tree species, to determine if a phylogenetic pattern of trait values exists, and, if so, to assess whether the rate of trait evolution varies across the phylogeny. The phylogenetic comparative analyses presented here confirm previous results that critical material properties are significantly correlated with one another and with wood density. Although the rates of trait evolution of angiosperms and gymnosperms (i.e., conifers) are similar, the material properties of both clades evolved in distinct selective regimes that are phenotypically manifested in lower values across all material properties in gymnosperms. This observation may be related to the structural differences between gymnosperm and angiosperm wood such as the presence of vessels in angiosperms. Explorations of rate heterogeneity indicate high rates of trait evolution in wood density in clades within both conifers and angiosperms (e.g., *Pinus* and *Shorea*). Future analyses are warranted using additional data given these preliminary results, especially because there is ample evidence of convergent evolution in the material properties of conifers and angiosperm wood that appear to experience similar ecological conditions.

Introduction

Whether it is a bone of a mammal (Swartz and Middleton 2008), the setae on the underside of a gecko’s foot (Gilman et al. 2015), or the trunk of a tree (Niklas 1992; Niklas and Spatz 2012), the material properties of cells, tissues, and organs play a critical role in determining how structures and organisms mechanically perform when subjected to external loads. However, unlike most animals that can use behavioral responses to alter or cope with the forces experienced in nature, plants deal with wide-ranging ecological conditions with little ability to adjust their location (Thibaut et al. 2001; van Gelder et al. 2006). Indeed, a terrestrial plant like an

oak tree may spend hundreds of years in the same location. Thus, determining how the material properties of plants have evolved is critical for understanding plant diversity and ecology (Niklas and Telewski 2022). Plant growth habits are extremely diverse, including trees, shrubs, herbs, vines, lianas, root climbers, epiphytes, hemi-epiphytes, and parasites. Additionally, their structure can vary within a species depending upon genomic composition, environmental conditions, and even age (Thibaut et al. 2001; Rowe and Speck 2005; Beekman 2016). The mechanical properties can differ considerably among the woody stems of trees, but they generally have relatively low stiffness, compared to other

Advance Access publication June 28, 2022

© The Author(s) 2022. Published by Oxford University Press on behalf of the Society for Integrative and Comparative Biology. All rights reserved. For permissions, please e-mail: journals.permissions@oup.com

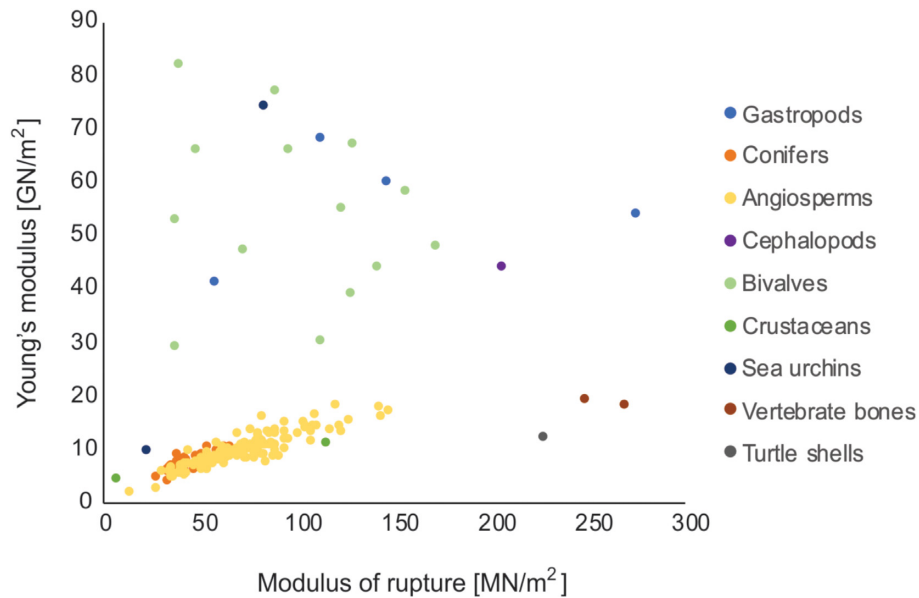

Fig. 1 Modulus of rupture plotted against Young's modulus for a variety of biological materials, including the conifers and angiosperms in our study. The turtle shell data are from [Magwene and Socha \(2013\)](#) and the remaining data are from Table 5.3 in [Wainwright et al. \(1976\)](#).

biomaterials ([Fig. 1](#)). They can, however, exhibit relatively high strengths compared to other materials. In addition to being important for a tree, the material properties of plants can dictate the interactions between animals and the surfaces on which they move ([Gilman and Irschick 2013](#); [Van Casteren et al. 2013](#); [Higham et al. 2017](#)). Beyond this, the stability of plants through time is critical for providing structure in ecosystems. Thus, evaluating the evolution of material properties has large-scale implications.

There are five biomechanical features that hold true for all terrestrial plants, regardless of their habitat or growth form (summarized in [Niklas 1992](#)): (1) they sustain two general categories of mechanical forces (static self-loading and dynamic wind-induced loads), (2) static self-loading and dynamic wind-induced loads are additive, (3) static loads increase slowly over time as plants increase in size (therefore, growth patterns can compensate for increasing self-loading), (4) dynamic loadings can change dramatically over short periods of time and are therefore unpredictable and potentially dangerous ([Niklas 2000](#); [Higham et al. 2021](#)), and (5) stems such as tree branches and trunks generally fail in torsion as a result of dynamic loads because plant tissues generally resist bending more than twisting (thus eccentric loadings are potentially dangerous). This raises the concept of the safety factor (*SF*) in plants such as trees. The *SF* is the ratio of the capability to resist forces to the actual forces experienced in nature ([Alexander 1981](#); [Niklas 2000](#); [Higham et al. 2021](#)). Higher values of *SF* indicate that a tree is more likely to withstand dynamic loadings.

The density of wood is highly correlated with the material properties that dictate the ability of stems (and roots) to resist bending or twisting ([Chave et al. 2009](#); [Niklas and Spatz 2010](#)), an ability that is important for evaluating and predicting the mechanical behavior of trees ([Dahle and Grabosky 2010](#)). Density also provides a measure of carbon storage, which is a critical variable in modeling ecosystem processes and tree construction costs. However, most comparisons of density to mechanical properties of wood have little direct bearing on understanding the biomechanics of living woody plants because these measurements are almost always based on kiln- or air-dried samples of wood whose mechanical attributes differ, often substantially, from hydrated tissue samples. For example, Young's modulus (see below) is greater for dried samples than those with the natural water content ([Mencuccini et al. 1997](#)). In addition, the magnitude of the self-loading of a living branch or tree trunk includes the amount of water contained within tissues.

In addition to tissue density, there are four other important mechanical (material) properties: (1) Young's modulus, E , which measures the ability of a simple or composite material (such as wood) to resist compression or tension (and thus bending; [Spatz et al. 1999](#)):

$$E = \frac{\sigma}{\varepsilon},$$

where σ is uniaxial stress (force per unit area) and ε is strain (e.g., the change in length divided by original length). Often simply termed the elastic modulus, E is typically measured as the slope of the stress-strain

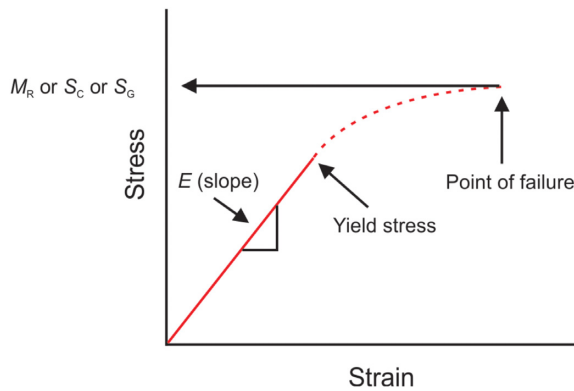

Fig. 2 The relationship between stress and strain during a material property test. The variables measured in our study are indicated on the curve. Young's modulus (E), or the modulus of elasticity, is the slope of the linear portion of the stress–strain curve. The other moduli are represented as maximum stress at the point of breakage. The moduli are for bending (M_R), compression (S_C), and torsion (S_G).

curve (Fig. 2). (2) The modulus of rupture, M_R , is the largest stress experienced at the moment of fracture in bending (Figs. 2). (3) The maximum strength in shearing, S_G , is the largest stress experienced in a material before it fails in torsion. (4) The maximum strength in compression, S_C , is the largest stress that occurs before a material fails under a compressive force. These four material properties are important because they collectively define the ability of any plant tissue to cope with bending or torsion. They therefore specify the ability of stems (and roots; see Stubbs et al. 2019) to cope with the mechanical forces created by self-loading and dynamic wind-induced pressure (dynamic drag forces).

Prior research has shown that tissue density and E , M_R , S_G , and S_C are highly correlated with one another (Niklas and Spatz 2010), so much so that the mechanical properties of wood can often be predicted to a reasonable extent if wood density is accurately measured (Steffenrem et al. 2007; Chave et al. 2009; Niklas and Spatz 2010). This not only applies to plants, but also bones of animals. For example, in a study of humans, horses, and bovines, the density of cancellous bone was positively and significantly correlated with Young's modulus (Hodgskinson and Currey 1992). This phenomenology becomes important because tissue density is the easiest among the five variables to measure accurately. It is, therefore, assumed that the density of green (naturally hydrated) wood is a useful proxy of E , M_R , S_G , and S_C . The strength of the relationship among some variables can, however, vary even within the same plant as a function of growth responses to gravity and dynamic loadings (Archer and Wilson 1973; Rowe and Speck 2005; Dahle and Grabosky 2010). In addition, some studies have found differences in mechanical properties due to factors other than density

(e.g., Voelker et al. 2011), and that the strength of the correlation between density and the different mechanical traits can differ (e.g., Steffenrem et al. 2007). Finally, few studies have incorporated phylogenetic history when examining the correlations among traits.

Land plants likely evolved tree size and shape many times independently, beginning with progymnosperms (e.g., *Archaeopteris*) and lycopsids in the Devonian (Meyer-Berthaud et al. 1999; Greb et al. 2006; Stein et al. 2020) and culminating within modern gymnosperms and angiosperms. However, it is poorly understood if all plants with tree-like growth converged on similar material properties. To initiate a systematic investigation of the evolution of material properties of trees, we used previously published data (Niklas and Spatz 2010) to explore the evolution of the biomechanical properties of green wood across angiosperms and conifers. We visualize the phylogenetic distribution of biomechanical properties across conifer and angiosperm trees, assess the phylogenetic signal contained within the distribution of material properties, and determine if the aforementioned traits are correlated after accounting for phylogenetic covariance. Based on prior research, we predicted that density would be positively correlated with mechanical properties, and that relatively high values of density, strength, and stiffness have evolved multiple times across the phylogeny.

Methods

Biomechanical data

The data used in this study, which span 20 conifer species and 64 angiosperm species, were taken from a compilation published by Niklas and Spatz (2010). The compilation consists primarily of the data from a forest product compendium (Lavers, 1969), which reports experimental data from many different laboratories. Additional data compiled by Niklas and Spatz (2010) came from unpublished tests in their laboratories or the laboratories of their colleagues. None of the species tabulated in the compendium is represented by more than three entries. However, the sample sizes measured for some mechanical properties exceed the number of species in the entire data set. Because the different wood samples were examined to determine different material properties in different laboratories, the sample sizes for the five variables of interest vary, albeit not significantly. For example, the most frequently measured material property was maximum compressive strength ($N = 178$), whereas the most infrequently reported material property was the maximum strength in shearing ($N = 165$).

The data accumulated in the Lavers (1969) compendium were gathered over a period of ~ 40 yr. It is impractical, therefore, to give a detailed account of how

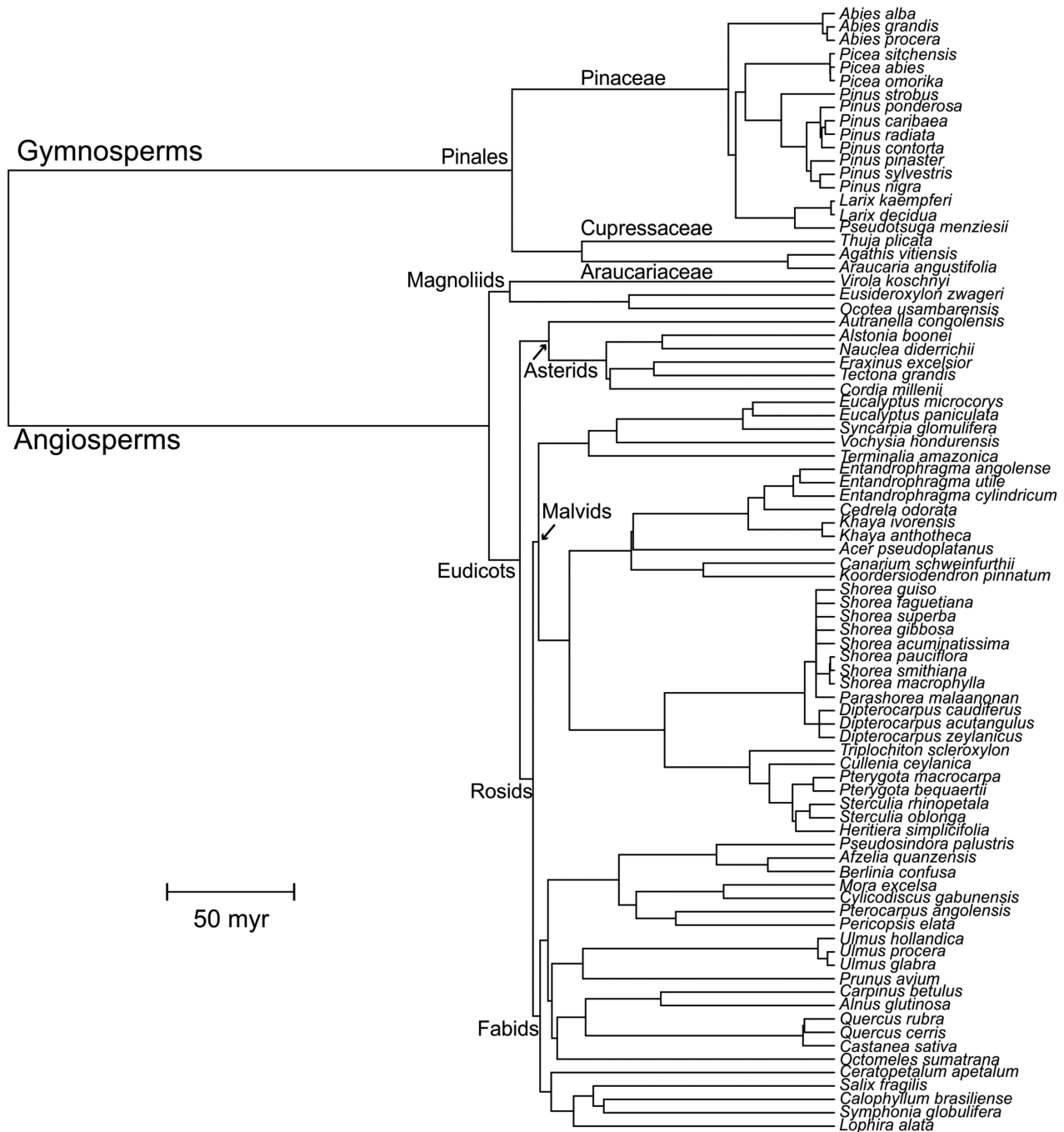

Fig. 3 The time-calibrated phylogeny used in this study. This phylogeny was pruned from [Smith and Brown \(2018\)](#) to match the species with data on material properties. The scale bar represents 50 million years.

each of the samples for which data are reported were gathered or tested. However, in general, logs from five or more trees of each species were selected and specimens of green wood were extracted randomly from each log. As noted by [Lavers \(1969\)](#) and others (e.g., [Niklas 1992](#)), differences among field sites and even between geographic regions are typically of less statistical significance than are differences among trees of the same species, while differences in the properties of

wood from different trees of the same species are generally greater than differences in the properties from different parts of the same tree.

Phylogenetic comparative methods

The time-calibrated seed plant phylogeny of [Smith and Brown \(2018\)](#) was used for all comparative analyses ([Fig. 3](#)). This large phylogeny is based on hierarchi-

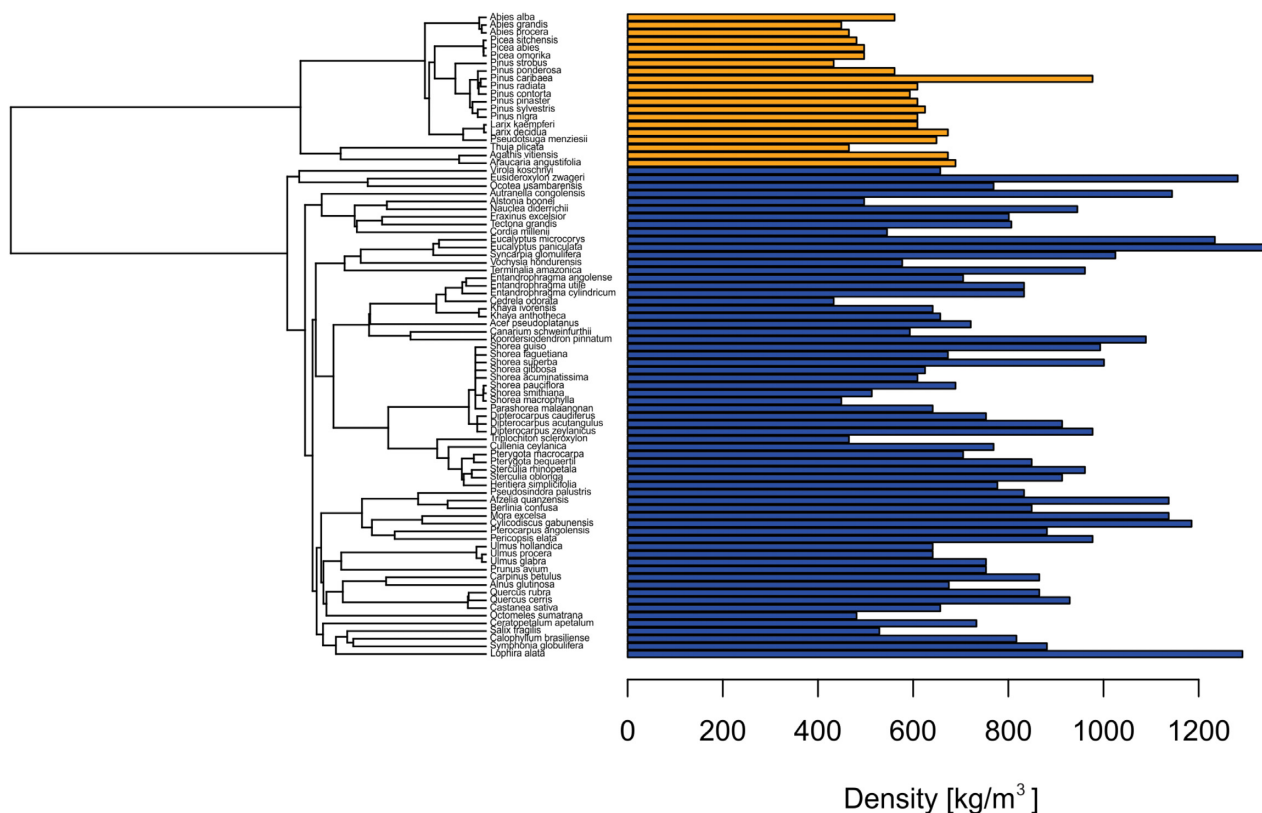

Fig. 4 Phylogenetic bar plot of the mean values for green wood density. The orange and blue bars are conifers and angiosperms, respectively.

cal clustering of molecular data, accessible at https://github.com/FePhyFoFum/big_seed_plant_trees, and includes 356,305 species. The phylogenetic distribution of material properties (species means) was visualized by plotting data aligned with the pruned phylogeny (Fig. 3) to check for the presence of phylogenetic clusters of low or high values. The phylogenetic signal in the data was also quantitatively estimated by calculating Pagel's λ (Pagel 1999) and Blomberg's K (Blomberg et al. 2003). Angiosperm and conifer trait values were compared with simulation-based phylogenetic ANOVAs (after Garland et al. 1993), implemented in phyttools (Revell 2012). Correlations between traits were tested through phylogenetic generalized least-squares (PGLS) analyses with a Brownian correlation structure (Symonds and Blomberg 2014). Data were also summarized by a phylogenetic principal component analysis using a correlation matrix (PCA; Revell 2009). The tempo and mode of trait evolution in angiosperms and conifers were compared with BROWNIE (O'Meara et al. 2006) implemented in phyttools (Revell 2012) and OUwie (Beaulieu and O'Meara 2021) while multivariate evolutionary models were assessed through mvMORPH (Clavel et al. 2015). Finally, as an exploratory tool, the heterogeneity of the rate of trait evolution was estimated (Revell 2021). Rate het-

erogeneity was estimated for log₁₀-transformed data, as raw data caused computational difficulties. Computations were stable for analyses with a penalty term of $\lambda = 0.1$ and 0.01 but other terms frequently caused computational problems. Future analyses with different approaches and large sample sizes are required to better understand the possible rate heterogeneity of material properties in trees. All visualizations and analyses were implemented in R 4.1.0 (R Core Team 2021), using the ape (Paradis and Schleip 2019), geiger (Harmon et al. 2008; Pennell et al. 2014), mvMORPH (Clavel et al. 2015), nlme (Pinheiro et al. 2021), OUwie (Beaulieu and O'Meara 2021), phyttools (Revell 2012), and rr2 (Ives and Li 2018) packages.

Results

Green wood density ranged from 433 to 1346 kg/m³, with a mean of 757.2 kg/m³ and a standard deviation of 222.5 kg/m³ (Fig. 4). Young's modulus ranged from 4600 to 18100 MN/m², with a mean of 9149 MN/m² and a standard deviation of 3002.2 MN/m² (Fig. 5). The modulus of rupture ranged from 28 to 143 MN/m², with a mean of 65.4 MN/m² and a standard deviation of 24.9 MN/m². Shear strength ranged from 4.3 to a maximum of 17.2 MN/m², with a mean of 8.5 MN/m²

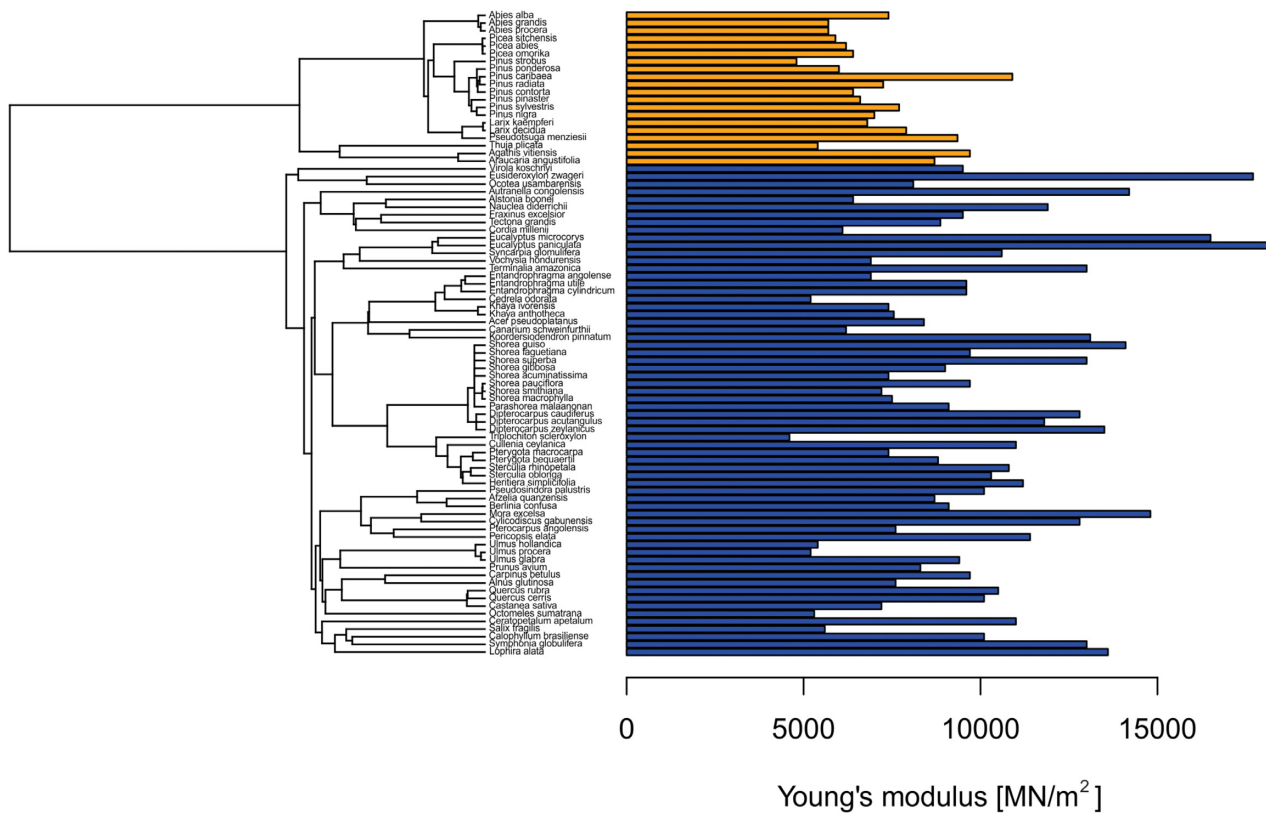

Fig. 5 Phylogenetic bar plot of the mean values of Young's modulus. The orange and blue bars are conifers and angiosperms, respectively.

and a standard deviation of 3.1 MN/m². Finally, compressive strength ranged from 13.9 to a maximum of 79.9 MN/m², with a mean of 32.3 MN/m², and a standard deviation of 14 MN/m².

For all variables, both conifers and angiosperms exhibited values at the upper end of the distribution found across all trees in our sample, although angiosperms frequently exhibited the highest values (Figs 4 and 5). For example, *Eucalyptus paniculata* had the highest density (1346 kg/m³) and E in the dataset, whereas *P. caribaea* had the highest value (977 kg/m³) for a conifer. *Eusideroxylon zwageri* exhibited the highest value of M_R (143 MN/m²). Additionally, relatively high values appeared several times across the phylogeny, suggesting independent origins. In comparison to other biomaterials, these values are still relatively low (Fig. 1).

All material properties contain a significant phylogenetic signal. Pagel's λ is similar for all material properties, ranging from 0.822 (Young's modulus) to 0.912 (compressive strength), in all cases suggesting significant phylogenetic signal in the data ($P < 0.001$) (Table 1). Similar results were obtained through calculations of Blomberg's K. Randomization tests of Blomberg's K with 1,000 simulations suggest significant phylogenetic signal in the data ($P = 0.001$) (Table 1).

Table 1 Phylogenetic signal in material properties of wood, estimated through two different metrics, Pagel's λ and Blomberg's K.

	Pagel's λ	Blomberg's K
Density	0.832	0.16
Young's modulus	0.822	0.147
Modulus of rupture	0.858	0.174
Shear strength	0.89	0.176
Compressive strength	0.912	0.191

In congruence with the presence of a phylogenetic signal, the phylogenetic barplots show a patterning of the data at the large phylogenetic scale. Conifers tend to have smaller values than angiosperms (Figs. 4 and 5). Boxplots confirm that gymnosperms tend to have lower values as angiosperms across all material properties (see Supplementary Appendix Figure). The results from phylogenetic ANOVA, which employs a simple Brownian motion model of evolution, do not support this pattern statistically. However, results from OUwie provide evidence that conifers and angiosperms have different selective regimes, with smaller values being selected for in conifers than in angiosperms. The OUM model, that is, and Ornstein-Uhlenbeck model of trait evolution with distinct selective regimes for angiosperms

Table 2 Akaike weights for a set of four different models.

	BMI	BMS	OUI	OUM
Density	0	0	0.01	0.99
Young's modulus	0	0	0.01	0.99
Modulus of rupture	0	0	0.11	0.89
Shear strength	0	0	0	1
Compressive strength	0	0	0.02	0.98

For all material properties, the best supported model, that is, the model with the largest Akaike weight, is the OUM model.

Table 3 Results of Phylogenetic least squares (PGLS) regressions among traits in our study (see text for abbreviations).

X	Y	Pagel's λ	Slope	P (slope)	R ²
ρ	E	0.71	12.4	<0.001	0.85
ρ	M_R	0.91	0.1	<0.001	0.92
ρ	S_G	0.67	0.012	<0.001	0.90
ρ	S_C	0.95	0.055	<0.001	0.90
E	M_R	0.96	0.007	<0.001	0.88
E	S_G	0.83	0.0008	<0.001	0.80
E	S_C	0.96	0.004	<0.001	0.87

and conifers receives the strongest support, with Akaike weights of at least 0.89 for all material properties (Table 2). This pattern is corroborated by multivariate approaches. Model fitting in mvMORPH also identified an OU model with two regimes as the best fitting model, with an Akaike weight of 0.77. The next best-fitting model was a single-regime OU model, with an Akaike weight of 0.23 (see Supplementary Appendix).

Density is a strong predictor of each of the material properties with little scatter around the fitted lines, and all of the material properties are correlated with one another (Fig. 6; Table 2), indicating a “systemic” evolution of material properties. The P -values for slopes being different from 0 are less than 0.001 for all tested trait pairs, indicating a “systemic” evolution of material properties (Table 3). This pattern is corroborated by the results from a phylogenetic PCA. The first principal component axis explains 91.3% of the variance in the data, and all material properties contribute with similar direction and magnitude to this axis (Supplementary Appendix). Angiosperms and conifers have different values for PC1.

The rate of trait evolution can best be described with an equal rate across all species in the dataset, at least concerning individual traits. The rates of trait evolution for all 5 material properties individually do not differ between angiosperms and conifers (see Appendix). However, evidence for rate heterogeneity in the data is provided by multirateBM, which offers insight into what parts of the phylogeny may feature a fast or a slow

evolution of material properties. The rates of evolution of the mechanical traits were relatively high in very specific regions of the phylogeny, irrespective of what material property was considered (Fig. 7). High rates of density evolution occurred in *Pinus* and *Shorea* (Fig. 7). The wood of *P. caribaea* was clearly denser, stronger, and stiffer than the wood samples of all other species in the genus. Some of the highest and lowest values of all traits were found among species in the genus *Shorea*. For M_R and E , there were three regions within the phylogenetic tree topology that exhibited high rates of evolution; these regions included the genera *Pinus*, *Shorea*, and *Ulmus* (Fig. 7).

Discussion

The wood in both conifers and angiosperms attains relatively high values of Young's modulus, modulus of rupture, maximum shear and compressive strength, and density, despite the fact that angiosperm wood typically contains vessels, whereas conifer wood contains only tracheids. Nevertheless, the highest values were all observed within the angiosperms, with only one species of pine (*P. caribaea*) reaching relatively similar values to that of angiosperms. Compared to other biomaterials, however, both groups exhibit relatively modest values (Fig. 1).

The differences between angiosperms and gymnosperms (i.e., conifers in our data set) in terms of wood structure may constrain the evolution of wood material properties in distinct ways. Modeling results from OUwie and mvMORPH strongly suggest that angiosperms and conifers experience different selective regimes. Across all traits, conifers had lower peak values than angiosperms. Note that phylogenetic ANOVAs failed to recover statistical support for differences between angiosperms and conifers. Given the unique shape of the phylogeny of the species in our dataset this result is not surprising. Angiosperms and conifers are the two major clades, each with a long independent evolutionary history, with long branches leading from the root to the most recent common ancestor of each respective clade. This tree shape is not unlike the tree of the “worst case” problem (Felsenstein 1985). Following the Brownian motion model implemented in phylogenetic ANOVA, the prolonged independent history of each clade all but dictates similar values within but different values between clades.

Our phylogenetic comparative analysis revealed that relatively high rates of trait evolution may have appeared multiple times across the phylogeny, within both angiosperms and conifers. This indicates the presence of regions of the phylogeny with significantly elevated rates of evolution and the possible convergence

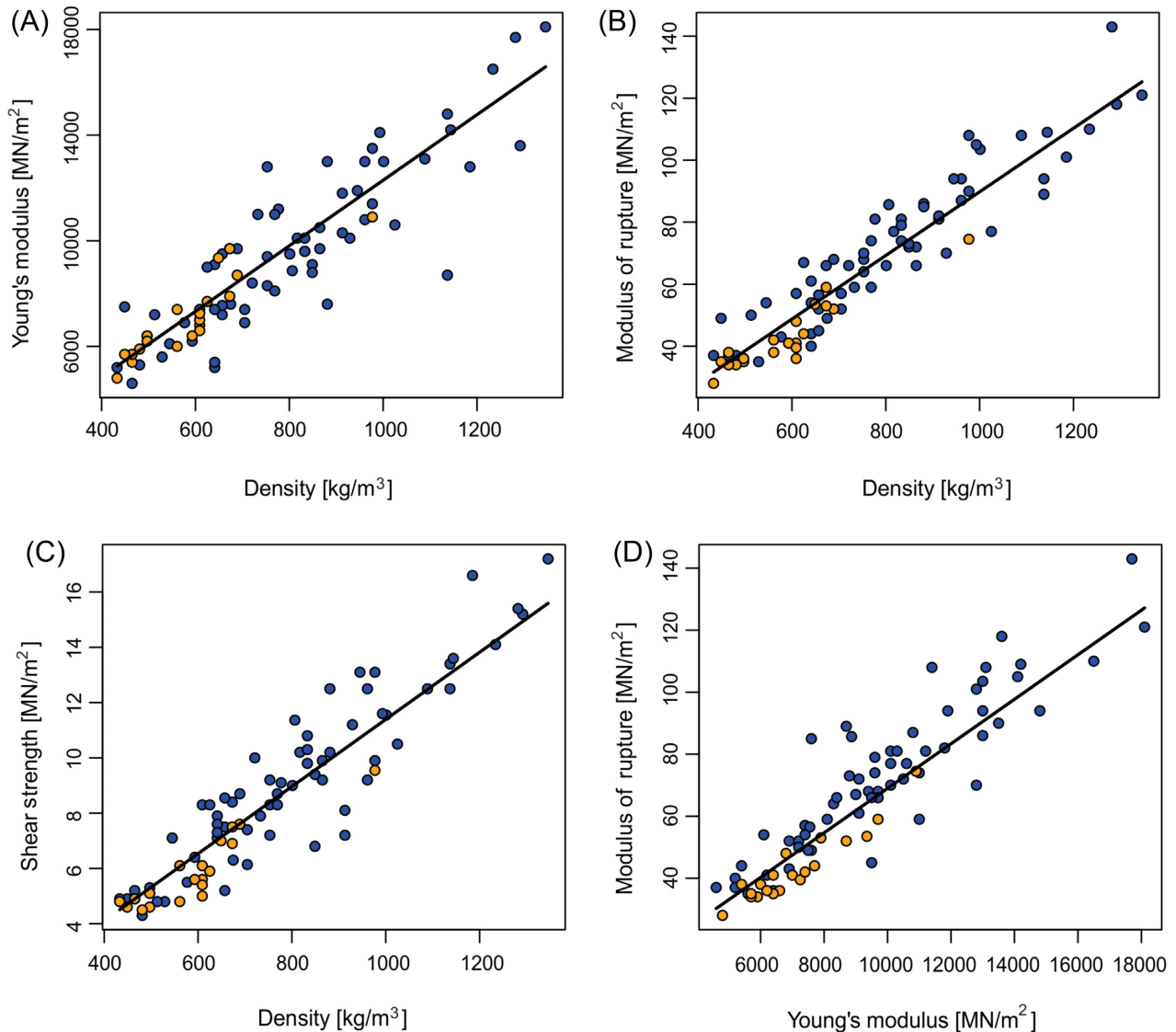

Fig. 6 PGLS regressions for selected traits in our study. Wood density and E (A), M_R (B), and S_G (C). Finally, the relationship between M_R and E is shown in D. The orange and blue circles are conifers and angiosperms, respectively.

of increased stem strength, stiffness, and density. The fact that both conifers and angiosperms attain relatively similar maximum values indicates that there are multiple solutions to the same problem (i.e., many-to-one mapping of form-to-function; see Niklas 1994 and Wainwright et al. 2005).

Correlations among traits

Strong correlations exist among all of the traits in the dataset, although the strength of these correlations varied across the traits, a pattern that has been observed in other studies. For example, the correlation between density and M_R was stronger than the correlation between density and E for Norway spruce (Steffenrem et al. 2007). We found a similar result, although not quite as extreme (Fig. 6). This is likely due to the fact that stiff-

ness is dependent upon many factors, including density, for example, the orientation of the cellulose microfibrils (MFA) in the S2 layer of the cell wall (Barnett and Bonham 2004). This is illustrated by studies of wood development in trees. In young saplings, MFA is high and E is low, allowing them to bend in response to wind-induced forces. Older and larger trees require greater stiffness, thus leading to lower MFA and higher E in the outer layers. A reduction in MFA from 40° to 10° in the core and outer layers, respectively, leads to an increase in cell wall stiffness five-fold (Cave 1968). It is possible that MFA varied across the trees in our study (particularly since there is no information about the age of wood samples used to determine material properties), and in relation to the growth conditions of the different species, but we do not have those data.

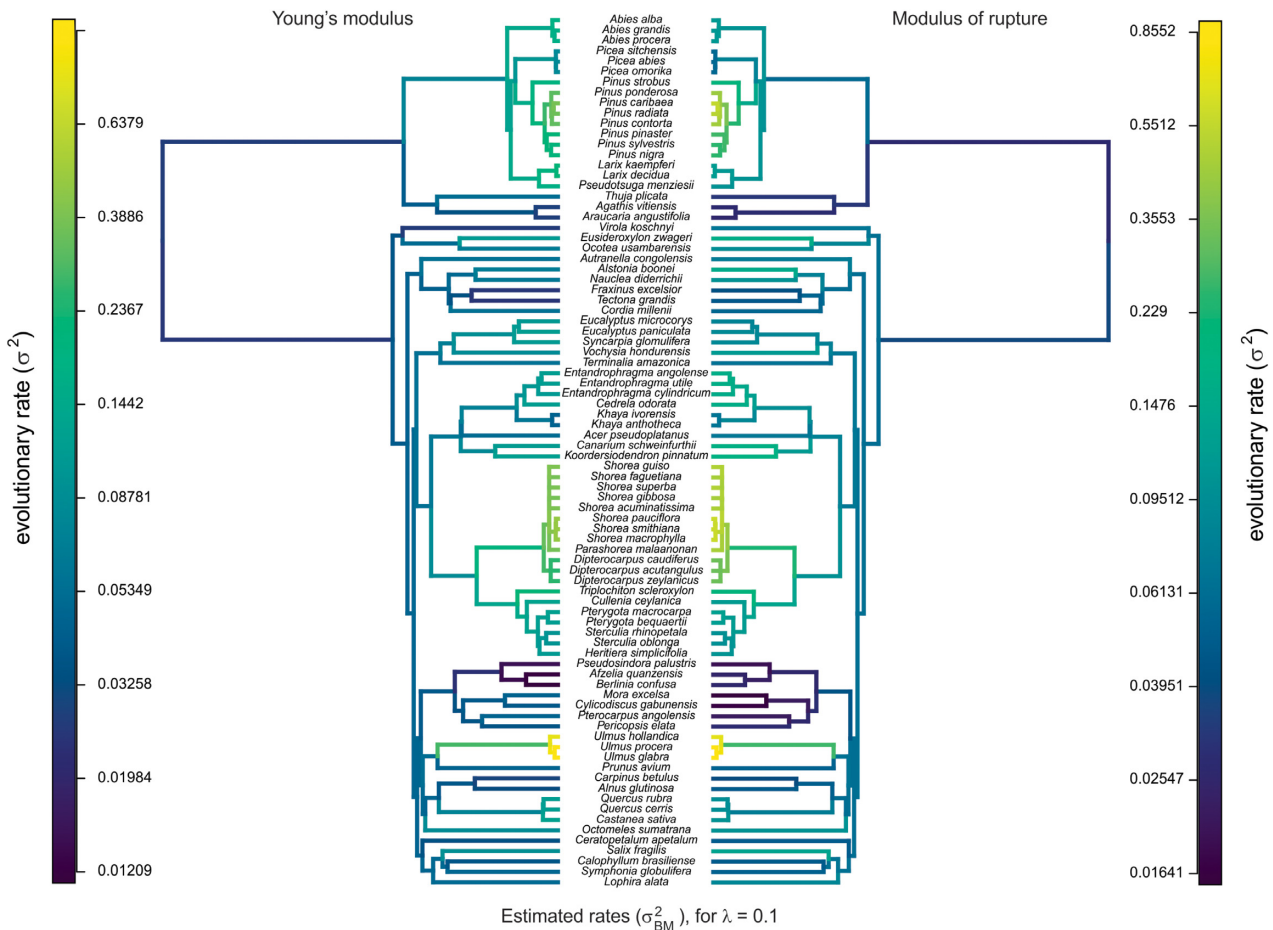

Fig. 7 Estimates of the rate heterogeneity for Young's modulus (left) and modulus of rupture (right), calculated with a penalty term of $\lambda = 0.1$. Elevated and slow rates tend for both material properties to occur in the same clades. Simulations suggest that this pattern is not generated by the topology and branch lengths of the phylogeny.

Why are there differences among studies? We offer two explanations. First, we used measurements of density on green wood, whereas almost all studies that have examined the correlation between density and mechanical traits have used measurements on dry wood. As discussed below, the latter does not reflect natural conditions, and may reduce the correlations among traits. We strongly advocate for the use of green wood when measuring mechanical properties and density. Second, our study is interspecific, whereas some of the weaker relationships have emerged from intraspecific studies, which might be expected given that each species of wood has a defined anatomy and thus a confined range of variation.

Multiple solutions to high density and increased strength

Conifers and angiosperms differ in many respects, as, for example, the nature of the cells conducting water. Conifers have tracheids, which are fusiform lignified cells with lateral perforations that function in both

transport and structural support (Sperry et al. 2006). Using *Pinus* as an exemplar, conifer wood consists predominantly of tracheids with a comparatively small volume fraction of fibers and ray parenchyma. The shear bulk of tracheids provides a porous sponge-like matrix for the transport of water that simultaneously provides mechanical resistance to bending and twisting. In contrast, angiosperm wood typically contains vessels composed of vessel members each of which is generally a wider cell-type with end-wall as well as lateral perforations. Generally, angiosperm wood consists predominantly of xylem fibers and ray parenchyma, and a comparatively small volume of vessels, which are more efficient in water transport compared to tracheids (Hacke et al. 2005). The multicellular vessels found in angiosperm wood almost exclusively transport water. Mechanical support comes from a dense matrix of xylem fibers. Despite these differences, the different types of wood are both very successful, albeit in different areas of the planet. Angiosperms are much more ecologically diverse, but conifers can form extensive forests in

cold, dry, and nutrient-poor habitats. The multiple solutions to structural support, as noted above, indicate that there are multiple ways to attain the same or very similar levels of mechanical and hydraulic function in trees (Wainwright et al. 2005).

Potential trade-offs between hydraulic conductance and density

As in most biological systems, trade-offs define evolutionary pathways. In many cases, the trade-off arises due to conflicting functional obligations. Multiple scenarios in plants will result in potential trade-offs. With the exception of parasitic species, plants perform four general tasks: (1) intercept radiant energy in the form of sunlight, (2) conduct fluids (e.g., water and cell sap), (3) sustain externally applied mechanical forces, and (4) reproduce (Niklas 2016). Among terrestrial plant species, successful reproduction ultimately depends on the performance of the three “vegetative” tasks. Likewise, the ability to intercept and use sunlight for photosynthesis depends on the ability to translocate fluids and the ability to cope with mechanical forces. Importantly, these two vegetative functions should be highly correlated in plant tissues, such as wood, because the mechanical and hydraulic properties of these tissues are interdependent at the cellular level (Niklas 1992).

Having more vessel lumen area indicates a greater capacity of wood to conduct water (Zimmermann 1983), but it also means there might be less room for structural elements. Indeed, wood density and vessel lumen area are often negatively correlated (Preston et al. 2006). This interdependence comes about because plant tissues (in the parlance of engineering) are cellular solids, that is, they consist of one or more solid phases (i.e., intra- and extracellular crystals and cell walls) and one or more fluid phases (i.e., water, air, and cytoplasm; Niklas 1992). The volumetric fraction of the solid phase and the fluid phase influence the mechanical and hydraulic properties of a tissue. In general, the ability of a tissue such as wood to cope with mechanical forces increases with an increasing volume of the solid phase, whereas the hydraulic conductivity of a plant tissue increases typically with an increasing volume fraction of the fluid phase, indicating a trade-off (Gleason et al. 2016). This phenomenology is particularly true for wood because the volume fraction of the fluid phase is largely contained in hydraulically specialized conducting cells (i.e., with rare exceptions, tracheids in gymnosperms and vessels in angiosperms). For example, a recent study found a trade-off between wood density and hydraulic efficiency in conifers (Pittermann et al. 2006). A systematic review of these potential trade-offs found a relatively weak correlation between safety and hydraulic efficiency, but

also found that no species had high efficiency and high safety, supporting the idea of a trade-off (Gleason et al. 2016). That said, quite a few species exhibited both low efficiency and low safety, raising important questions about ecological contexts. Despite the competing requirements between density and hydraulic conductance, not all studies have found a significant trade-off. In a study of 42 rainforest trees, there was a small, but non-significant, correlation between wood density and potential hydraulic conductance (K_p) (Poorter et al. 2010).

Although we did not quantify hydraulic conductance, it would seem safe to assume, based on the fact that most studies have identified a trade-off, that species with relatively high values of density, such as *E. paniculata*, will have correspondingly lower values of hydraulic conductance. However, the data reported by Ziemińska et al. (2013) indicate that wood density is the result of a complex suite of chemical and structural features and thus an emergent functional trait, particularly in medium-density species. Indeed, Jagels and Visscher (2006) report a synchronous increase in mechanical support and hydraulic conductive capacity for *Metasequoia glyptostroboides* as a consequence of compensatory changes in the proportions of primary and secondary wall thickness, and not as a consequence of changes in specific gravity, secondary wall microfibril angle, lignin content, or other factors. Consequently, future investigation is needed regarding the relationships among wood density, mechanical stiffness, and conductance. Certainly, having narrower transport cells is beneficial in some circumstances. In areas where freezing might occur, narrower vessels (more closely approximating tracheids) might be beneficial. Indeed, this is an explanation for why conifers may have an advantage in these cooler areas, i.e., their water conducting cells are less prone to freezing-induced embolisms compared to vessels.

Yet another important tradeoff is the relationship between Young's modulus, E , and density, ρ , as illustrated by considering the Euler-Greenhill formula, which estimates the maximum critical height, H_{crit} , to which a vertical column can be elevated before it undergoes Euler buckling, that is,

$$H_{crit} = C(E/\rho)^{1/3}D^{2/3},$$

where C is a numerical unitless factor determined by the taper of a column and D is the diameter at the base of the column. The tradeoff here is contained within the quotient E/ρ , wherein the two variables are positively correlated, that is, given the positive correlation, any increase in Young's modulus necessarily requires an increase in density. Clearly, reducing the density of a material, even a composite material (e.g.,

wood) reduces the unit weight of the structure (e.g., tree trunk), which is beneficial. However, this reduction comes at the cost of a reduced ability to cope with bending.

Ecological correlations with material properties

Angiosperms dominate most temperate and tropical vegetation, but conifers can out-complete them in high latitudes and elevations, or where the soil is nutrient poor (Bond 1989). Where conifers are dominant, they often occur in monotypic stands with large numbers of individuals. However, some species of conifers occupy tropical regions, and may provide an important window into the relationship between ecology and mechanical properties. For example, *P. caribaea* forests are relatively common in eastern Honduras and Nicaragua (Clewell 1986). A study contrasted the damage incurred by mixed tropical rain forest and pine forest (*P. caribaea*) in Nicaragua when Hurricane Joan struck in 1988 (Boucher et al. 1990), and found that more damage was experienced by rain forest trees than pine trees, but that uprooting was more common in pine trees. This implies that the stems of the pine trees were likely stronger and more resistant to breakage. *Pinus caribaea* was, by far, the strongest, stiffest, and most dense conifer in our dataset. Given its exposure to hurricane-force winds (in this case, exceeding 250 km/h), its mechanical and functional traits might enhance its ability to survive. A future study that generates an ecomechanical model of the maximum breaking stress of pine trees relative to the potential wind speeds experienced in nature, as in Higham et al. (2021), would reveal whether *P. caribaea* is indeed better at resisting the drag-induced dynamic forces imparted by hurricane winds.

Some of the highest rates of trait evolution in our study are found within the genus *Ulmus*. This is likely due to the almost doubling of Young's modulus in *U. glabra* compared to the other two species. Although there is no direct evidence for why this species would exhibit much higher values of stiffness, it does have the widest range of all the European elms and reaches its northern limit above the Arctic circle (Thomas et al. 2018). It is the only elm native to Ireland. Whether widespread species that experience a wide range in ecological conditions commonly exhibit greater values of mechanical properties is not known, but this genus might be a great target for future biogeographical and ecomechanical studies.

It is well known that trees exhibit varying levels of stiffness, in part due to ecological factors such as wind exposure (Brüchert and Gardiner 2006). That said, trees

are not simply stiffer in areas of high wind exposure. In a study of Sitka spruce from different levels of wind exposure found that stem tapering was greater, and flexural stiffness was lower, in the trees with highest exposure. This allowed a stiff base, but flexibility in higher regions (Brüchert and Gardiner 2006). This highlights the importance of understanding intraspecific variation in mechanical properties and responses to wind-induced bending. In a study of wind-induced stresses in cherry trees, Niklas and Spatz (2000) found that wind-load stress levels vary along the length of the trunk and branches. They also found that stress levels would rise to a catastrophic level if it were not for ontogenetic changes in stem taper and canopy shape that reduce stress. It would be intriguing to incorporate measures of stem taper with the mechanical properties in our dataset.

We do not have measurements of maximum height for the species in our dataset, but previous work has observed mixed results when comparing maximum adult height to wood density. In a study of 38 species of rain forest trees in Malaysia, there was a negative correlation between wood density and maximum tree height (Thomas 1996). It is thought that the understory consisted of slower-growing and more dense trees, whereas the tallest trees grew fast, but at the cost of decreased stem density. This is consistent with the idea that species tolerant of low resource availability have lower inherent growth and mortality rates (Poorter et al. 2008). In the current study, *P. caribaea* is the strongest and most dense, but reaches mature heights that exceed other species of pine. Thus, it is possible that other ecological factors can drive increased density and strength.

We propose that an in-depth investigation of the correlations among the specific anatomical features of woods, mechanical properties, and ecological variables associated with the biogeographic ranges of species is warranted. Consider, for example, the anatomy of *Shorea* and *P. caribaea* wood, which our study highlights as very different from its closest relatives. Some species of *Shorea* have very thick-walled fibers, with high specific gravities (Pande et al. 2005). *Pinus caribaea*'s mechanical properties depend on the habitat in which the plant grows, something akin to southern hard pines, in that the wood has a distinct latewood zone with very thick-walled longitudinal tracheids and also a high proportion of compression wood (in leaning trunks), which typically has thicker than normal tracheids. The wood of both taxa is highly responsive to local environmental conditions and the orientation of trunks. These anatomical and ecological features suggest possible explanations for the unique wood properties of these two taxa.

Green versus dried wood in mechanical testing

Mechanical testing of plant material can be done in multiple ways. Often, dry wood samples are used. This is problematic as dry wood does not reflect the properties under natural conditions. Green (fresh) wood samples, as in our study, will provide a more accurate measure of properties in nature. As noted by Niklas and Spatz (2010), the stiffness and strength of wood increases as the moisture content of wood decreases. As E increases, the difference between green and hydrated and dried wood increases. Thus, there are several factors that stress the importance of measuring functional traits on wood in its natural state.

Summary and future directions

We have illustrated that the evolution of density and other mechanical traits varies across tree species, with multiple incidences of potentially elevated rates of evolution. Incorporating phylogenetic information eroded the differences in trait values between conifers and angiosperms, highlighting the importance of including phylogenetic information when assessing mechanical traits. However, our dataset is limited by sample size, which limits the ability to characterize the tempo and mode of trait evolution. We also note that the species in this study are not a random sample across plants, as only plants with tree size and shape were selected. Future studies should incorporate a larger dataset, focusing on the density of green wood across phylogenetically and ecologically diverse species. Given the very strong correlation among all of the traits in our study, focusing on density alone should prove to be fruitful. That said, adopting an integrative and whole-organism approach to tree biomechanics, of which material properties are only a part, will provide key insight into resistance to bending and self-loading forces in nature (Fournier et al. 2013; Higham et al. 2021). The following are key future directions:

(1) Combining biomechanics and ecology. Although we discuss possible ecological factors that might play a role in driving increased density, strength, and stiffness, a formal ecological framework would be beneficial. Numerous databases now exist that outline the temperature, average and maximum wind speeds, precipitation, and other factors across the globe. Ecological niche modeling could be used to determine how the fine-scale distribution of trees is linked to mechanical properties. Ecomechanical models could be used to estimate how ecological variables would influence the biomechanical response of trees (Higham et al. 2021). Capitalizing on large databases, such as the Global

Biodiversity Information Facility (GBIF), will be important.

- (2) Additional functional traits. There are numerous additional traits that should be examined in relation to the functional traits in our study. These include crown lateral expansion, buttressing, tapering, the degree of stem curvature, maximum tree height, and others (Niklas 1992; Fournier et al. 2013). It is possible that factors like buttressing, the existence of lateral flanges joining the roots and trunk, may influence the mechanical behavior of a stem when subjected to external dynamic forces. It has been suggested that buttresses can reduce the tensile stresses developing within the root system (Henwood 1973), but it is clear that the influence of buttressing is more complex. Whether or not buttresses fail at the plates will depend on a number of factors, including buttress shape and the ontogenetic stage of the species (Clair et al. 2003). Many of the tropical species in our dataset have buttressing, but it is unclear how that might have influenced our results.
- (3) Ecologically relevant measures of mechanical properties. As noted earlier, the condition of the specimen (green *versus* dried) is important when considering the ecological relevance of the results, but another consideration is how the traits are measured. We used data that involves samples from trees. More recent studies simply measure the mechanical properties (e.g., Young's modulus) of trees that are still standing (Brüchert et al. 2000; Clair et al. 2003). In these cases, a known bending force is applied to the tree and strain sensors are attached to the stem. These *in vivo* measurements are analogous to bone strain measurements inside of an animal during natural activity (e.g., Blob and Biewener 1999), which provide important information about complex responses to external loads. However, as noted by Clair et al. (2003), small strains that are non-destructive only provide general information about failure risks, although they do provide information about strain anywhere within the stem. To fully understand how trees fail under large strains, destructive experiments are needed, which are more difficult. Regardless, future studies that combine *in vivo* and *in vitro* measurements of mechanical properties (and compare them) will provide very important information about complex stem properties.

Acknowledgments

We also thank the reviewers for their insightful comments that improved our manuscript.

Funding

Our symposium was supported by the Company of Biologists and the Society for Integrative and Comparative Biology.

Supplementary Data

Supplementary data available at [ICB](#) online.

Conflicts of Interest

Authors declare no competing interests.

Data Availability Statement

No new data were used in this study.

References

- Alexander RM. 1981. Factors of safety in the structure of animals. *Sci Prog* 67:109–30.
- Archer RR, Wilson BF. 1973. Mechanics of compression wood response. II. Location, action, and distribution of compression wood formation. *Plant Physiol* 51:777–82.
- Barnett JR, Bonham VA. 2004. Cellulose microfibril angle in the cell wall of wood fibres. *Biol Rev* 79:461–72.
- Beaulieu JM, O'Meara B. 2021. OUwie: analysis of evolutionary rates in an OU framework. *R package version 2.6*. <https://github.com/thej022214/OUwie>.
- Beckman H. 2016. Wood anatomy and trait-based ecology. *IAWA J* 37:127–51.
- Blob RW, Biewener AA. 1999. *In vivo* locomotor strain in the hindlimb bones of *Alligator mississippiensis* and *Iguana iguana*: implications for the evolution of limb bone safety factor and non-sprawling limb posture. *J Exp Biol* 202:1023–46.
- Blomberg SP, Garland T, Jr, Ives AR. (2003). Testing for phylogenetic signal in comparative data: behavioral traits are more labile. *Evolution* 57:717–45.
- Bond WJ. 1989. The tortoise and the hare: ecology of angiosperm dominance and gymnosperm persistence. *Biol J Linn Soc* 36:227–49.
- Boucher DH, Vandermeer JH, Yih K, Zamora N. 1990. Contrasting hurricane damage in tropical rain forest and pine forest. *Ecology* 71:2022–4.
- Brüchert F, Becker G, Speck T. 2000. The mechanics of Norway spruce [*Picea abies* (L.) Karst]: mechanical properties of standing trees from different thinning regimes. *Forest Ecol Manag* 135:45–62.
- Brüchert F, Gardiner B. 2006. The effect of wind exposure on the tree aerial architecture and biomechanics of Sitka spruce (*Picea sitchensis*, Pinaceae). *Am J Bot* 93:1512–21.
- Cave ID. 1968. The anisotropic elasticity of the plant cell wall. *Wood Sci Technol* 2:268–78.
- Chave J, Coomes D, Jansen S, Lewis SL, Swenson NG, Zanne AE. 2009. Towards a worldwide wood economics spectrum. *Ecology Letters* 12:351–66.
- Clair B, Fournier M, Prevost MF, Beauchene J, Bardet S. 2003. Biomechanics of buttressed trees: bending strains and stresses. *Am J Bot* 90:1349–56.
- Clavel J, Escarguel G, Merceron G. 2015. mvmorph: an R package for fitting multivariate evolutionary models to morphometric data. *Methods Ecol Evol* 6, 1311–9.
- Clewell AF. 1986. Observations on the vegetation of the mosquitia in Honduras. *Sida* 11:258–70.
- Dahle GA, Grabosky JC. 2010. Variation in modulus of elasticity (E) along *Acer platanoides* L. (Aceraceae) branches. *Urban For Urban Green* 9, 227–33.
- Felsenstein J. 1985. Phylogenies and the comparative method. *Am Nat* 125:1–15.
- Fournier M, Dlouha J, Jaouen G, Almeras T. 2013. Integrative biomechanics for tree ecology: beyond wood density and strength. *J Exp Bot* 64, 4793–815.
- Garland T, Jr, Dickerman AW, Janis CM, Jones JA. 1993. Phylogenetic analysis of covariance by computer simulation. *Syst Biol* 42:265–92.
- Gilman CA, Imburgia MJ, Bartlett MD, King DR, Crosby AJ, Irschick DJ. 2015. Geckos as springs: mechanics explain across-species scaling of adhesion. *PLoS One* 10: e0134604.
- Gilman CA, Irschick DJ. 2013. Foils of flexion: the effects of perch compliance on lizard locomotion and perch choice in the wild. *Funct Ecol* 27, 374–81.
- Gleason SM, Westoby M, Jansen S, Choat B, Hacke UG, Pratt RB, Bhaskar R, Brodribb TJ, Bucci SJ, Cao KF et al. 2016. Weak tradeoff between xylem safety and xylem-specific hydraulic efficiency across the world's woody plant species. *New Phytol* 209:123–36.
- Greb SF, DiMichele WA, Gastaldo RA. 2006. Evolution and importance of wetlands in earth history. *Geological Society Special Paper* 399:1–40.
- Hacke UG, Sperry JS, Pittermann J. 2005. Efficiency versus safety tradeoffs for water conduction in angiosperm vessels versus gymnosperm tracheids. In: Holbrook NM, Zwieniecki MA, editors. *Vascular transport in plants: a volume in physiological ecology*. Academic Press, Oxford. p. 333–53.
- Harmon LJ, Weir JT, Brock CD, Glor RE, Challenger W. 2008. GEIGER: investigating evolutionary radiations. *Bioinformatics* 24:129–131.
- Henwood K. 1973. A structural model of forces in buttressed tropical rain forest trees. *Biotropica* 5:83–93.
- Higham TE, Ferry LA, Schmitz L, Irschick DJ, Starko S, Anderson PSL, Bergmann PJ, Jamniczky HA, Monteiro LR, Navon D et al. 2021. Linking ecomechanical models and functional traits to understand phenotypic diversity. *Trends Ecol Evol* 36:860–73.
- Higham TE, Russell AP, Niklas KJ. 2017. Leaping lizards landing on leaves: escape-induced jumps in the rainforest canopy challenge the adhesive limits of geckos. *J R Soc Interface* 14:20170156.
- Hodgkinson R, Currey JD. 1992. Young's modulus, density, and material properties in cancellous bone over a large density range. *J Mater Sci Mater Med* 3:377–81.
- Ives AR, Li D. 2018. rr2: An R package to calculate R2s for regression models. *J Open Source Software* 3:1028. <https://rdr.io/github/arives/rr2/man/rr2.html>.
- Jagels R, Visscher GE. 2006. A synchronous increase in hydraulic conductive capacity and mechanical support in conifers with relatively uniform xylem structure. *Am J Bot* 93: 179–87.

- Lavers GM. 1969. The strength properties of timbers. 2nd ed. London, UK: Her Majesty's Stationary Office.
- Magwene PM, Socha JJ. 2013. Biomechanics of turtle shells: how whole shells fail in compression. *J Exp Zool A Ecol Integr Physiol* 319:86–98.
- Mencuccini M, Grace J, Fioravanti M. 1997. Biomechanical and hydraulic determinants of tree structure in scots pine: anatomical characteristics. *Tree Physiol* 17:105.
- Meyer-Berthaud B, Scheckler SE, Wendt J. 1999. *Archaeopteris* is the earliest known modern tree. *Nature* 398:700–1.
- Niklas KJ, Spatz H-C. 2000. Wind-induced stresses in cherry trees: evidence against the hypothesis of constant stress levels. *Trees* 14: 0230–7.
- Niklas KJ, Spatz H-C. 2010. Worldwide correlations of mechanical properties and green wood density. *Am J Bot* 97:1587–94.
- Niklas KJ, Spatz H-C. 2012. *Plant Physics*. Chicago (IL): The University of Chicago Press.
- Niklas KJ, Telewski FW. 2022. Environmental-biomechanical reciprocity and the evolution of plant material properties. *J Exp Bot* 73:1067–79.
- Niklas KJ. 1992. *Plant biomechanics: an engineering approach to plant form and function*. Chicago (IL): University of Chicago Press.
- Niklas KJ. 1994. Morphological evolution through complex domains of fitness. *Proc Natl Acad Sci* 91:6772–9.
- Niklas KJ. 2000. Computing factors of safety against wind-induced tree stem damage. *J Exp Bot* 51:797–806.
- Niklas KJ. 2016. *Plant Evolution: An Introduction to the History of Life*. Chicago (IL): University of Chicago Press.
- O'Meara B, Ane C, Sanderson MJ, Wainwright PC. 2006. Testing for different rates of continuous trait evolution using likelihood. *Evolution* 60:922–33.
- Pagel M. 1999. Inferring the historical patterns of biological evolution. *Nature* 401:877–84.
- Pande PK, Negi K, Singh M. 2005. Intra- and Inter-species Wood Anatomical Variation in Balau Group of Shorea of Malay Peninsula. *Indian For* 131: 1041–8.
- Paradis E, Schliep K. 2019. ape 5.0: an environment for modern phylogenetics and evolutionary analyses in R. *Bioinformatics* 35:526–528.
- Pennell MW, Eastman JM, Slater GJ, Brown JW, Uyeda JC, FitzJohn RG, Alfaro ME, Harmon LJ. 2014. geiger v2.0: an expanded suite of methods for fitting macroevolutionary models to phylogenetic trees. *Bioinformatics* 30:2216–2218.
- Pinheiro J, Bates D, DebRoy S, Sarkar D. 2021. Package "nlme", linear and nonlinear mixed effects models. <https://cran.r-project.org/web/packages/nlme/index.html>.
- Pittermann J, Sperry JS, Wheeler JK, Hacke UG, Sikkema EH. 2006. Mechanical reinforcement of tracheids compromises the hydraulic efficiency of conifer xylem. *Plant Cell Environ* 29:1618–28.
- Poorter L, McDonald I, Alarcon A, Fichtler E, Licona J-C, Penaclos M, Sterck F, Villegas Z, Sass-Klaassen U. 2010. The importance of wood traits and hydraulic conductance for the performance and life history strategies of 42 rainforest tree species. *New Phytol* 185:481–92.
- Poorter L, Wright SJ, Paz H, Ackerly DD, Condit R, Ibarra-Manríquez G, Harms KE, Licona JC, Martínez-Ramos M, Mazer SJ et al. 2008. Are functional traits good predictors of demographic rates? evidence from five neotropical forests. *Ecology* 89:1908–20.
- Preston KA, Cornwell WK, DeNoyer JL. 2006. Wood density and vessel traits as distinct correlates of ecological strategy in 51 California coast range angiosperms. *New Phytol* 170:807–18.
- R Core Team 2021. R: a language and environment for statistical computing. Vienna: R foundation for statistical computing. <https://www.r-project.org/>.
- Revell LJ. 2009. Size-correction and principal components for interspecific studies. *Evolution* 63:3258–68.
- Revell LJ. 2012. phytools: An R package for phylogenetic comparative biology (and other things). *Methods Ecol Evol* 3:217–23. <http://www.phytools.org/>.
- Revell LJ. 2021. A variable-rate quantitative trait evolution model using penalized likelihood. *PeerJ* 9:e11997.
- Rowe N, Speck T. 2005. Plant growth forms: an ecological and evolutionary perspective. *New Phytol* 166:61–72.
- Smith SA, Brown JW. 2018. Constructing a broadly inclusive seed plant phylogeny. *Am J Bot* 105:302–14.
- Spatz H-C, L. K, Niklas KJ. (1999. Mechanical behavior of plant tissues: composite materials or structures? *J Exp Biol* 202:3269–72.
- Sperry JS, Hacke UG, Pittermann J. 2006. Size and function in conifer tracheids and angiosperm vessels. *Am J Bot* 93, 1490–500.
- Steffenrem A, Saranpaa P, Lundqvist S-O, Skróppaa T. 2007. Variation in wood properties among five full-sib families of Norway spruce (*Picea abies*). *Ann For Sci* 64:799–806.
- Stein WE, Berry CM, Morris JL, VanAller Hernick L, Mannoni F, Ver Straeten C, Landing E, Marshall JEA, Wellman CH, Beerling DJ et al. 2020. Mid-Devonian *Archaeopteris* roots signal revolutionary change in earliest fossil forests. *Curr Biol* 30:421–431.e2.
- Stubbs CJ, Cook DD, Niklas KJ. 2019. A general review of the biomechanics of root anchorage. *J Exp Bot* 70:3439–51.
- Swartz SM, Middleton KM. 2008. Biomechanics of the bat limb skeleton: scaling, material properties and mechanics. *Cells Tissues Organs* 187:59–84.
- Symonds MRE, Blomberg SP. 2014. A primer on phylogenetic generalised least squares. In: Garamszegi LZ, editor. *Modern phylogenetic comparative methods and their application in evolutionary biology*. Berlin: Springer. p. 105–30
- Thibaut B, Gril J, Fournier W. 2001. Mechanics of wood and trees: some new highlights for an old story. *Comptes Rendus de la Academie des Science sere II Fascicule B-Mechanique* 329:701–16.
- Thomas PA, Stone D, La Porta N. 2018. Biological flora of the British Isles: *Ulmus glabra*. *J Ecol* 106:1724–66.
- Thomas SC. 1996. Asymptotic height as a predictor of growth and allometric characteristics in Malaysian rain forest trees. *Am J Bot* 83:556–66.
- Van Casteren A, Sellers WI, Thorpe SKS, Coward S, Crompton RH, Ennos AR. 2013. Factors affecting the compliance and sway properties of tree branches used by the Sumatran orangutan (*Pongo abelii*). *PLoS One* 8:e67877.
- van Gelder HA, Poorter L, Sterck FJ. 2006. Wood mechanics, allometry, and life-history variation in a tropical rain forest tree community. *New Phytol* 171:367–78.
- Voelker SL, Lachenbruch B, Meinzer FC, Strauss SH. 2011. Reduced wood stiffness and strength, and altered stem form, in young antisense *4CL* transgenic poplars with reduced lignin contents. *New Phytol* 189:1096–109.

- Wainwright PC, Alfaro ME, Bolnick DI, Hulsey CD. 2005. Many-to-one mapping of form to function: a general principle in organismal design? *Integr Comp Biol* 45:256–62.
- Wainwright SA, Biggs WD, Currey JD, Gosline JM. 1976. *Mechanical design in organisms*. New York(NY): John Wiley & Sons, Inc.
- Ziemińska K, Butler DW, Gleason SM, Wright IJ, Westoby M. 2013. Fibre wall and lumen fractions drive wood density variation across 24 Australian angiosperms. *AoB PLANTS* 5:PLT046.
- Zimmermann MH. 1983. *Xylem structure and the ascent of sap* 1-146. Berlin: Springer-Verlag.